



## **2022 MID-EAST 602 LATE MODELS RULE BOOK**

### ***A NOTE FROM THE SANCTIONING BODY:***

A MID-EAST 602 LATE MODEL EVENT IS A COMPETITIVE RACING EVENT, WHICH IS INTENDED TO BE CONDUCTED AND OFFICIATED IN ACCORDANCE WITH THE RULES HEREIN (THE 2021 MID-EAST 602 LATE MODEL RULE BOOK). THESE RULES PROVIDE GUIDELINES FOR ALL EVENTS. THE RULEBOOK MAY BE AMENDED FROM TIME-TO-TIME AND SPECIAL RULES MAY BE PUBLISHED AND/OR ADJUSTED AT ANY EVENT WITH THE PARTICIPANTS RECEIVING PRIOR NOTIFICATION. BY PARTICIPATING IN THESE EVENTS, ALL PARTICIPANTS AGREE TO COMPLY WITH THESE RULES AND REGULATIONS. THE RULES ARE NOT INTENDED TO EXPRESS OR IMPLY THE WARRANTY OF SAFETY OF HARDWARE OR SOFTWARE AS A RESULT OF PUBLICATION OF, OR COMPLIANCE WITH THE RULES AND REGULATIONS AS STATED HEREIN. THE RULES ARE INTENDED TO OFFER A GUIDELINE FOR THE CONDUCT AND OFFICIATING OF AN EVENT. THE SERIES DIRECTOR SHALL BE EMPOWERED TO PERMIT ANY REASONABLE AND/OR APPROPRIATE AMENDMENT FROM ANY OF THE SPECIFICATIONS AND/OR PROCEDURES HEREIN, OR IMPOSE ANY FURTHER RESTRICTIONS THAT IN THEIR OPINION DOES NOT ALTER THE MINIMUM ACCEPTABLE REQUIREMENTS. REVISIONS TO THE RULES ARE NOT INTENDED TO EXPRESS OR IMPLY THE WARRANTY OF SAFETY SHALL NOT RESULT FROM ANY SUCH DEVIATION OR RESTRICTION OF THE SPECIFICATIONS, RULES AND/OR PROCEDURES. ANY INTERPRETATION OF, DEVIATION FROM, THESE RULES HEREIN, ARE LEFT TO THE DISCRETION OF THE RACING OFFICIALS AND THEIR JURISDICTION IS FINAL. IT IS ULTIMATELY THE OBLIGATION OF EACH PARTICIPANT TO ENSURE THEIR CONDUCT AND EQUIPMENT COMPLIES WITH ALL OF THE APPLICABLE RULES, AS THEY MAY BE AMENDED FROM TIME-TO-TIME.

THANK YOU FOR YOUR CONTINUED SUPPORT

### **WEEKLY RACING PROCEDURES ARE AT THE DISCRETION OF THE HOST TRACK. THE BELOW PROCEDURES APPLY AT ALL MID-EAST 602 LATE MODEL TOURING EVENTS.**

#### **1.0 GENERAL RULES**

1. DRUG AND ALCOHOL CONSUMPTION WILL NOT BE TOLERATED. THOSE FOUND UNDER THE INFLUENCE WHILE RACING WILL NOT RACE AND COULD FACE FINES AND/OR SUSPENSION.
2. EVERYONE MUST HAVE A 1099/W9 ON FILE TO PARTICIPATE
3. ANYTHING THAT COULD BE CONSIDERED UNSPORTSMANLIKE CONDUCT WILL NOT BE TOLERATED.
  - a. THIS INCLUDES, BUT IS NOT LIMITED TO, FIGHTING AND VERBAL ALTERCATIONS. THIS ALSO INCLUDES SOCIAL MEDIA NETWORKS, AND WILL BE LEFT UP TO THE DISCRETION OF THE SERIES STAFF.
4. THOSE USING INAPPROPRIATE AND/OR FOUL LANGUAGE TOWARDS ANOTHER COMPETITOR OR FAN MAY RECEIVE ONE WARNING, AFTER THAT YOU WILL BE DISQUALIFIED, WITH NO POINTS OR MONEY BEING AWARDED.
5. CURSING OR ASSAULTING ANY MID-EAST 602 LATE MODELS SERIES OFFICIAL WILL RESULT IN AN AUTOMATIC DISQUALIFICATION, AND/OR SUSPENSIONS/PENALTIES. THIS WILL BE LEFT UP TO THE SERIES DIRECTOR'S DISCRETION.
6. ALL CARS ENTERED INTO MID-EAST COMPETITION MUST PAY THE \$50 YEARLY WEEKLY MEMBERSHIP FEE TO MID-EAST PRIOR TO TECHNICAL INSPECTION.
7. MEDIA, STREAMING AND ALL OTHER DIGITAL RIGHTS ARE RESERVED TO MID-EAST AND MID-EAST MEDIA DESIGNEES.
8. THE RULES AND/OR REGULATIONS SET FORTH HEREIN DO NOT EXPRESS OR IMPLIED WARRANTY OF SAFETY FROM PUBLICATION OF OR COMPLIANCE WITH RULES AND/OR REGULATIONS. THESE RULES ARE INTENDED AS A GUIDELINE FOR THE CONDUCT OF MID-EAST SANCTIONED 602 LATE MODEL DIVISION EVENTS, AND ARE IN NO WAY A GUARANTEE AGAINST INJURY OR DEATH TO PARTICIPANTS, SPECTATORS, OR OFFICIALS.

9. THE RULES AND/OR REGULATIONS WILL APPLY TO ALL MID-EAST 602 LATE MODEL SANCTIONED EVENTS.
10. MID-EAST OFFICIALS SHALL HAVE FULL AUTHORITY OVER SAID SANCTIONED EVENTS, AND IN THE EVENT OF ANY DISPUTE, THE HEAD OFFICIAL'S DECISION WILL BE FINAL.
11. ALL COMPETITORS AND CARS ARE SUBJECT TO INSPECTION BY MID-EAST TECHNICAL INSPECTORS OR THEIR REPRESENTATIVES AT ANY TIME DURING ANY EVENT.
12. MID-EAST, AND IT'S OFFICIALS AND REPRESENTATIVES RESERVE THE RIGHT TO CONFISCATE ANY SUSPICIOUS OR DEEMED ILLEGAL PARTS OR COMPONENTS.
13. MID-EAST RESERVES THE RIGHT TO ALTER OR AMEND THESE RULES AND/OR REGULATIONS IN THE INTEREST OF FAIR COMPETITION, EFFICIENT COMPLETION OF AN EVENT, OR FOR SAFETY. ALL OFFICIAL'S DECISIONS ARE FINAL.
14. IN ADDITION TO THIS RULE BOOK, CRATE RACIN' USA SUSPENSIONS AND FINES WILL BE UPHELD IN THE "MID-EAST REGION".

## **2.0 RACING RULES**

1. RACING RULES INCLUDING STARTS, RESTARTS ETC ARE AT THE DISCRETION OF THE HOST TRACK FOR WEEKLY RACING.
2. TOURING SERIES PROCEDURES COMING SOON.

## **3.0 RACING PROCEDURES**

1. RACE PROCEDURES ARE AT THE DISCRETION OF THE HOST TRACK FOR WEEKLY RACING.
2. TOURING SERIES PROCEDURES COMING SOON.

## **4.0 POST-RACE INSPECTION**

1. TO PROMOTE A COMPETITIVE ENVIRONMENT THE TOP 5 WILL BE SUBJECT TO TECHNICAL INSPECTION AT ANY TIME.
2. HOST TRACK TECH PROCEDURES MAY APPLY.
3. THOSE FAILING TO TECH WILL BE DISQUALIFIED AND/OR SUSPENDED ACCORDING TO THE RULE BOOK.
  - a. DRIVERS WILL BE GIVEN 30 MINUTES OF COOLDOWN AND 1 HOUR AFTER THE PROTEST IS FILED TO PRESENT THE PART(S)

## **5.0 PROVISIONALS**

1. PROVISIONALS ARE AT THE DISCRETION OF THE HOST TRACK FOR WEEKLY RACING.
2. TOURING SERIES PROCEDURES COMING SOON.

## **6.0 AMENDMENTS/REVISIONS FOR 2020**

1. ALL REVISIONS WILL BE HIGHLIGHTED IN RED AND LISTED IN SECTION 6.0

## **7.0 POINTS AND INCIDENT POINTS**

1. 2020 POINTS FUND CRITERIA
  - a. DRIVERS MUST COMPETE IN 12 EVENTS DURING THE 2020 WEEKLY MID-EAST 602 LATE MODELS SEASON TO BE ELIGIBLE TO RECEIVE BANQUET AWARDS OR SPECIAL CATEGORY AWARDS FOR THE 2020 CHAMPIONSHIP.
2. EARNING POINTS
  - a. EVERY DRIVER RECEIVES SOME POINTS AS LONG AS THEY PAY THE MEMBERSHIP FEE, ENTRY FEE AND ARE DOCUMENTED AS COMPLETING IN (AT LEAST) TIME TRIALS, A HEAT RACE, OR A B-MAIN.
  - b. OVERALL FAST QUALIFIER WILL RECEIVE TWO (2) POINTS FOR SETTING FAST TIME PER EVENT.
  - c. B-MAIN POINTS WILL BE AWARDED AS FOLLOWS TO B-MAIN NON-TRANSFERS: (FOUND IN THE POINTS SPREADSHEET)
  - d. TO RECEIVE B-MAIN POINTS, DRIVERS MUST START THE B-MAIN EVENT.
  - e. PROVISIONAL AND TRANSFERS ONLY RECEIVE FEATURE POINTS.
  - f. A-MAIN POINTS WILL BE AWARDED AS FOLLOWS: (FOUND IN THE POINTS SPREADSHEET)
3. THE WORST FINISH WILL BE DROPPED FOR PERFECT ATTENDANCE DRIVERS, EXCLUDING DISQUALIFICATIONS.
4. WE WILL FOLLOW THE POINTS FUND PROVIDED IN THE POINTS SPREADSHEET.

## **8.0 INCIDENT POINTS**

1. INCIDENT POINTS AND REMOVAL FROM RACING SURFACE ARE AT THE DISCRETION OF THE HOST TRACK FOR WEEKLY RACING.
2. TOURING SERIES PROCEDURES COMING SOON.

## **9.0 DECALS**

1. DECAL AND CONTINGENCY REQUIREMENTS
  - a. THERE ARE CERTAIN DECALS THAT WILL BE ISSUED TO YOU AT EACH RACE AND MUST BE CARRIED ON THE CAR; IN ORDER TO EARN BOTH POINTS TOWARDS THE SEASON ENDING CHAMPIONSHIP PAYOUT AND EVENT PRIZE MONEY. THE SERIES IS AWARE OF AND HAS NO WISH TO CAUSE CONFLICTS BETWEEN DRIVERS, TEAMS AND YOUR SPONSORS. THESE DECALS MUST BE

PRESENT ON THE CAR FOR CONSIDERATION FOR SEASON ENDING CHAMPIONSHIP POINTS FUND. THESE DECALS MUST BE POSITIONED ON THE CAR SIDES. THE MID-EAST 602 LATE MODEL SHIELD MUST BE IN PLACE AT ALL EVENTS. THE SHIELD MUST BE PLACED ON THE FENDER ON THE RIGHT AND LEFT SIDES. COLORS MAY NOT BE CHANGED WHATSOEVER.

- b. DRIVERS WILL RECEIVE 1 EVENT GRACE PERIOD TO GET THEIR CARS WITH OUR DECALS IN COMPLIANCE WITH THE RULE BOOK. OTHERWISE THEY ARE SUBJECT TO FORFEIT CHAMPIONSHIP POINTS PER EVENT. (ALL LOGOS CAN BE FOUND IN THE DRIVE OR ON OUR WEBSITE AND ARE ALSO AVAILABLE AT THE TRACK.)

### **10.0 MEMBERSHIP**

1. ALL DRIVERS PARTICIPATING AT MID-EAST 602 LATE MODEL SANCTIONED TRACKS AND EVENTS MUST PURCHASE AN ANNUAL MEMBERSHIP AT A COST OF \$50 PER YEAR. THIS MEMBERSHIP MAKES THE DRIVER ELIGIBLE FOR POINTS FUND MONIES AND CONTINGENCY AWARDS.
2. MEMBERSHIPS ARE CONSIDERED LICENSED AND CAN BE REVOKED AT ANY TIME AT THE SANCTIONING BODY'S DISCRETION.
3. IN ADDITION TO THE REQUIRED MEMBERSHIP FEE, DRIVERS MAY BE SUBJECT TO TRACK ENTRY FEES ETC.

### **11.0 602 LATE MODEL RULES**

#### **11.0.1 SAFETY: ANY CAR DEEMED UNSAFE OR UNFIT FOR COMPETITION MAY NOT PARTICIPATE. MINOR INFRACTIONS WILL BE ISSUED A ONE (1) WEEK "FIX IT NOTICE"**

1. ALL BALLAST MUST BE SECURELY FASTENED WITH BOLTS AND/OR WEIGHT CLAMPS. DUCT TAPE AND ZIP TIES ARE NOT ACCEPTABLE. MUFFLER CLAMPS ARE NOT ACCEPTABLE. 1 MOUNTING POINT PER 25LBS REQUIRED.
2. BALLAST MUST BE PAINTED WHITE WITH CAR # DISPLAYED. ANY LEAD OR WEIGHT THAT COMES OFF OF A CAR IS SUBJECT TO A \$5/LB FINE.
3. MUST HAVE WORKING FIRE EXTINGUISHER IN CAR, UNLESS RUNNING FIRE SUPPRESSION SYSTEM.
  - a. FIRE SUPPRESSION SYSTEM WILL BE MANDATORY IN THE FUTURE, PLEASE INVEST IN ONE OVER THE NEXT SEASON.
4. MUST HAVE SFI APPROVED 5 POINT HARNESS THAT IS IN DATE. (3 YEARS OLD MAXIMUM)
5. MUST HAVE A WORKING RACECEIVER/NITRO BEE/SWITCH AT ALL TIMES WHILE ON THE RACING SURFACE. TUNED TO 454.000
6. FULL CONTAINMENT SEATS AND HEAD RESTRAINT REQUIRED AT ALL TIMES.
  - a. RACING SEATS REQUIRED, MUST FIT DRIVER, BE SFI APPROVED, AND MUST BE BOLTED TO ROLL CAGE.
7. CARS DEEMED UNSAFE TO RUN OR THAT FAIL PRETECH WILL NOT BE ALLOWED TO RACE AT THE TECH OFFICIALS DISCRETION.
8. NO ALUMINUM OR TITANIUM CAGES OR TUBING PERMITTED. ALL TUBING MUST BE A MINIMUM OF 1 1/2 INCHES AND A MINIMUM OF .095 WALL THICKNESS. THREE BARS IN DRIVER'S SIDE MANDATORY, TWO BARS IN RIGHT SIDE MANDATORY. MUST HAVE A MINIMUM OF 1 INCH BAR, .083 WALL THICKNESS IN HALO SECTION RUNNING EITHER FRONT TO REAR OR DIAGONAL ACROSS. MUST HAVE A ROCK GUARD WITH A MAXIMUM OF 4IN BETWEEN BARS.

#### **11.1 WEIGHT:**

**CLAIMED WEIGHT MUST BE POSTED CLEARLY ON BOTH SIDES OF A-PILLAR OR HOOD**

1. **2400 LBS - (1) LR SHOCK - NO TRACTION SHOCK**
2. **2450 LBS - (2) LR SHOCKS - TRACTION SHOCK**
3. **1LB PER LAP BURNOFF FOR MID-EAST SEALED ENGINES.**

#### **11.2 CHASSIS AND FRAME:**

1. CONVENTIONAL STYLE LATE MODEL OF ANY YEAR PERMITTED.
2. MID EAST WILL FOLLOW WORLD OF OUTLAW FRAME AND CHASSIS RULES. MUST MEET ALL SAFETY STANDARDS AT ALL TIMES.
3. ALL CARS MUST HAVE A SUITABLE AND DEEMED SAFE STEEL ROLL CAGE PROTECTING THE DRIVER'S COMPARTMENT.

**11.3 BODY NON-PROTEST ITEM GOVERNED BY MID EAST OFFICIALS:** THOUGH THEY MAY NOT BE PROTESTED THE BODIES MAY BE OBSERVED, MEASURED, ETC. AS NECESSARY. IF MID EAST OFFICIALS DO NOT APPROVE, YOU WILL BE ASKED TO CHANGE IT, ADD WEIGHT OR ANYTHING DEEMED NECESSARY BY THE OFFICIALS. WORLD OF OUTLAWS BODY RULES APPLICABLE AT ALL TIMES.

1. **GENERAL BODY:**
  - a. FINS AND LIPS WILL NOT BE PERMITTED ANYWHERE ALONG THE ENTIRE LENGTH OF THE CAR, UNLESS OTHERWISE NOTED.
  - b. BODIES THAT ARE NOT APPROVED MAY BE ASSESSED WITH 10LBS PER INCH OF INFRACTION.
  - c. REFER TO ATTACHED ILLUSTRATIONS FOR MEASUREMENTS
2. **SPOILER**
  - a. MAXIMUM 8 INCH SPOILER. MUST MEET WoO SPECIFICATIONS AND DRAWINGS.
3. **DECK HEIGHT**
  - a. MAXIMUM 39 INCHES

#### **11.4 CHASSIS & SUSPENSION:**

1. STANDARD LATE MODEL SUSPENSION ONLY. NO SPRING LOADED OR SHOCK TYPE 4 BAR RODS. ONLY STANDARD SOLID 4 BAR RODS.
2. STANDARD LATE MODEL SUSPENSION EQUALS ONE (1) SHOCK PER WHEEL. LEFT REAR IS ALLOWED ONE (1) SHOCK. **TWO (2) LR SHOCKS MAY BE UTILIZED HOWEVER THERE WILL BE A 50LB WEIGHT PENALTY ASSESSED. (SEE 11.1.2)**
  - a. SHOCKS MUST BE MOUNTED VERTICAL TO AXLE TUBE.
3. CHAIN LIMITERS WILL BE ALLOWED; MUST MEET THE FOLLOWING CRITERIA:
  - a. NO GAS OR SPRINGS WITHIN LIMITING DEVICE.
  - b. RUBBER PUCKS ARE PERMITTED.
4. NO TORSION BAR ON FRONT OR REAR SUSPENSION.
5. STANDARD ONE-PIECE BIRD CAGES. NO SPLIT BIRD CAGES.
6. CHASSIS BRACKETS MUST BE FIXED. NO MOVEMENT.
7. ONE (1) MECHANICAL TRACTION DEVICE ALLOWED, EITHER 5TH COIL OR TORQUE LINK, BUT NOT BOTH. ONE (1) 90/10 ALLOWED WITH TORQUE LINK, MOUNTED CENTER TOP OF REAR END TO FRAME.
8. ONE (1) COIL SPRING PER WHEEL.
  - a. ONE (1) RUBBER BUMP STOP ON THE RIGHT FRONT SHOCK PERMITTED. SHIMS PERMITTED FOR TRAVEL.
  - b. NO PROGRESSIVE SPRINGS, NO STACKING SPRINGS.
    - i. **ONE (1) 5LB MAXIMUM TAKE-UP SPRING MAY BE UTILIZED TO KEEP THE SPRING SEATED.**
  - c. ONE SPRING PER SHOCK; BARREL COIL SPRINGS PERMITTED.
9. SHOCK SLEEVE PROTECTOR ALLOWED TO PROTECT THE BODY OF SHOCK.
10. NO DATA ACQUISITION DEVICES OF ANY TYPE ALLOWED.
11. 250LB MINIMUM RIGHT FRONT SPRING AT ALL TIMES.
  - a. 10LB TOLERANCE FOR WEAR.

#### **11.5 SHOCK RULE:**

1. ONE (1) ALUMINUM OR STEEL NON ADJUSTABLE/NON CANISTER SHOCK PER CORNER.
  - a. NO "AIR SHOCKS" OR SHOCKS WITH MORE THAN 250LBS OF PRESSURE (EXTENDED AT ROOM TEMP)
  - b. CONVENTIONAL SHOCKS ONLY. SHOCK BODY MUST MATCH SHAFT SIZE. 6 IN 6, 7 IN 7 ETC.
  - c. SHOCK MUST BE SYMMETRICAL FROM TOP TO BOTTOM. MAY RUN SCREW ON CAP.
  - d. NO BULB STYLE SHOCKS.
  - e. IMCA/SCHRADER VALVE PERMITTED.
  - f. ONE RUBBER BUMP STOP PER SHOCK.
2. ONE (1) SHOCK WILL BE PERMITTED AT EACH FRONT WHEEL
3. ONE (1) WILL BE PERMITTED AT EACH REAR WHEEL.
  - a. WHEN UTILIZING ONE (1) SHOCK AT THE LEFT REAR WHEEL, THE SHOCK MUST BE MOUNTED BEHIND THE REAR AXLE TUBE.
  - b. ONLY ONE (1) SHOCK WILL BE ALLOWED AT THE LEFT REAR WHEEL. MAY RUN CHAIN LIMITER IN PLACE OF THE TRACTION SHOCK BUT IT MUST MEET THE CRITERIA (SECTION 11.4.3)
  - c. **TWO (2) LR SHOCKS MAY BE UTILIZED HOWEVER THERE WILL BE A 50LB WEIGHT PENALTY ASSESSED. (SEE 11.1.2)**
4. ONE (1) SHOCK WILL BE PERMITTED MID-SHIP AT THE FRONT OF THE LIFT ARM ASSEMBLY.

#### **11.6 IGNITION:**

1. ANY DISTRIBUTOR, MODULE, COIL ETC. (NO MAGNETOS, CRANK TRIGGER SYSTEMS) IGNITION BOXES PERMITTED. BILLET DISTRIBUTORS PERMITTED.
2. FIRING ORDER MUST REMAIN STOCK. (I.E CHEVROLET: **1-8-4-3-6-5-7-2**)
3. NO ELECTRONIC TRACTION CONTROL DEVICES. \$100 PROTEST FEE, SERIES RETAINS PROTEST FEE.
4. **EFFECTIVE IN 2022, THE FOLLOWING IGNITION BOXES WILL NOT BE PERMITTED FOR USE**
  - a. MSD 6530
  - b. MSD 65303
  - c. MSD DIGITAL PROGRAMMABLE 6AL-2
  - d. FAST IGNITION 307222
  - e. **ANY BOX THAT CHANGES OR HAS THE ABILITY TO CHANGE THE IGNITION ADVANCE IS NOT PERMITTED.**

#### **11.7 CARBURETOR:**

1. ONE 4 BARREL CARBURETOR ONLY.
2. NO SUPERBOWL OR SUPERBOWL STYLE CARBURETORS.
3. WILLY'S EQUALIZER PERMITTED.
4. GM 602 ENGINES PERFORM BEST WITH 650CFM HOLLEY CARBURETORS.
5. MAXIMUM 1" CARB SPACER ALLOWED.

### **11.8 EXHAUST SYSTEM:**

1. (1) MUFFLER PER HEADER ALLOWED.
2. STANDARD 4 INTO 1 ONLY. TRY Y'S AND OTHER MERGE STYLE HEADERS NOT PERMITTED.
3. NO EVAC SYSTEMS.

### **11.9 FUEL SYSTEM:**

1. RACING FUEL OR PUMP GAS ONLY.
2. FUEL IS SUBJECT TO LABORATORY TESTING AND FUEL MAY NOT CONTAIN ANY ADDITIVES.
  - a. THE SPECIFIC ELEMENTS WHICH WILL BE SEARCHED FOR INCLUDE: PROPYLENE OXIDE, ALCOHOLS (ALL TYPES), ALDEHYDES, AMINOBIPHENYL, BENZENE (IN EXCESS OF EPA LIMIT), BENZIDINE, BERYLLIUM COMPOUNDS, BROMINE COMPOUNDS, BUTADIENES, CHLORINATED COMPOUNDS, CHROMATES, DIOXANES, ETHYL ACRYLATE, ETHYLENE OXIDE, HYDRAZINE COMPOUNDS, METHYLENE DIANILINE, NAPHTHYLAMINE, NITROGEN COMPOUNDS (NITROMETHANE, ET AL.), STYRENES, TOLUIDINE AND XYLIDINE. ALSO ADDED THIS LIST WILL BE SUBSTANCES DEEMED TO EXCEED THE THRESHOLD LIMIT VALUES (TLV) OR BIOLOGICAL EXPOSURE INDICES (BEI) AS LISTED BY THE AMERICAN CONFERENCE OF GOVERNMENTAL INDUSTRIAL HYGIENISTS (ACGIH).
  - b. FUEL MUST MEET SPECIFIC GRAVITY AT ALL TIMES.
  - c. FUELS MUST MEET MANUFACTURER'S BENCHMARK AT ALL TIMES.
  - d. **GASOLINE OR RACE GAS** – SPECIFIC GRAVITY NOT TO EXCEED .744 AT 60 DEGREES. ANY GASOLINE OR RACE GAS WITH A SPECIFIC GRAVITY OF .745 OR GREATER WILL BE DISQUALIFIED. FUEL IS SUBJECT TO TESTING ON SITE, OR FUEL SAMPLES MAY BE TAKEN AND SENT TO AN INDEPENDENT LAB FOR TESTING. B. E-85 – SPECIFIC GRAVITY NOT TO EXCEED .7855
  - e. **E-85** – SPECIFIC GRAVITY NOT TO EXCEED .7855 AT 60 DEGREES. ANY E-85 WITH A SPECIFIC GRAVITY OF .7856 OR GREATER WILL BE DISQUALIFIED.
3. FUEL IS SUBJECT TO TESTING ON SITE, OR FUEL SAMPLES MAY BE TAKEN AND SENT TO AN INDEPENDENT LAB FOR TESTING.
4. IN-LINE FUEL SHUT OFF WITHIN REACH OF DRIVER RECOMMENDED.

### **11.10 DRIVELINE:**

1. ALL CARS MUST HAVE SAFETY LOOP FOR DRIVESHAFT.
  - a. DRIVESHAFT MUST BE CARBON FIBER OR ALUMINUM.

### **11.111 TRANSMISSION:**

1. ANY BERT, BRINN, FALCON OR SIMILAR TRANSMISSION WITH FORWARD AND REVERSE.
2. CARS MUST START AND MOVE UNDER THEIR OWN POWER, NO DIRECT DRIVES OR IN-AND-OUTS
3. CARBON FIBER MANDATORY WITH BALL SPLINE TRANSMISSIONS

### **11.12 BRAKES:**

1. CARS MUST HAVE WORKING BRAKES. SHUTOFF AND ADJUSTER PERMITTED.
2. STEEL ROTORS ONLY.
3. NO EXOTIC BRAKE SYSTEMS.

### **11.13 TIRES & WHEELS:**

1. HOOSIER SPEC HTS 1350/CRATE21 MANDATORY AT ALL TIMES
2. HOOSIER SPEC HTS 1600/CRATE55 MANDATORY ON RIGHT REAR.
3. 15X14 WHEELS ONLY, ANY OFFSETS PERMITTED, SPACERS PERMITTED.
4. **GROOVING AND SIPING PERMITTED.**
5. SUBJECT TO CHEMICAL LAB TESTING, REQUIRED TO CONFORM TO BENCHMARK AT ALL TIMES.
  - a. LAB RESULTS ARE INDEPENDENT AND THE LAB HAS FINAL SAY ON WHETHER THE TIRE HAS BEEN ALTERED.

### **11.14 ENGINE:**

NO ALUMINUM PARTS AT ANY TIME UNLESS OTHERWISE SPECIFIED.

1. **GM 602 CRATE SPEC ENGINE.**
  - a. SHALL MEET FACTORY "YELLOW GM BOOK" SPECS AT ALL TIMES WITH NO ALTERATIONS OR REMOVAL OF ANY PARTS.

- b. MUST BE FACTORY SEALED WITH GM BOTTLE CAP SEALS OR HAVE MID-EAST SEALS. ALL OTHER SEALS MUST RECEIVE WRITTEN APPROVAL PRIOR TO COMPETITION.

#### **11.15 OIL SYSTEMS:**

1. WET SUMP STOCK PUMP ONLY. NO EXTERNAL OIL PUMPS OR SYSTEMS (EVEN IF CONSIDERED "WET").
2. OIL COOLERS AND REMOTE OIL FILTERS PERMITTED.

#### **11.16 PROTEST AND CLAIM: ITEMS NOT COVERED BELOW ARE NON-PROTEST ITEMS AND WILL BE GOVERNED BY MID EAST AND ITS DESIGNEES.**

##### **1. FACTORY SEALED AND RE-SEALED CRATE ENGINES WILL FOLLOW CRATE CLAIM PROCEDURES AS FOLLOWS:**

###### **602- \$4200 OR CURRENT COST FROM DEALER (CITY CHEVROLET)**

- a. THE SANCTIONING BODY RESERVES THE RIGHT TO IMPOUND AND INSPECT ANY CRATE ENGINE AT ANY TIME AND WILL DO SO FREQUENTLY. ANY CRATE ENGINE ENTERED INTO MID EAST COMPETITION IS SUBJECT TO BE IMPOUNDED AND CHECKED AT ANY TIME.
  - i. WE BELIEVE IT IS THE DUTY OF THE SANCTIONING BODY TO POLICE CRATE ENGINES.
  - ii. IN THE EVENT THAT THE ENGINE COMES BACK LEGAL, MID EAST WILL WAIVE MID-EAST SEAL FEE AND SEND GASKETS TO THE TEAMS CERTIFIED REBUILDER OF CHOICE.
- b. ENGINE WILL BE RECEIVED WITH ACCESSORIES AS SUPPLIED FROM GM.
  - i. ONLY HIGHEST FINISHING CRATE ENGINE MAY BE CLAIMED. ONLY DRIVER ON THE SAME LAP CAN CLAIM. IF MORE THAN ONE PERSON CLAIMS, THE DRIVER FINISHING THE FARTHEST BACK GETS 1ST CHOICE.

##### **2. SHOCK CLAIM:**

###### **a. 1 SHOCK CLAIM \$250 PER SHOCK**

- i. CAR CLAIMING SHOCK(S) MUST FINISH IN THE TOP 5 AND ON THE LEAD LAP. CLAIMS MUST BE MADE TO TECH OFFICIAL WITHIN 10 MINUTES AFTER THE CAR CROSSES THE SCALES
- ii. NO REVERSE SHOCK CLAIMS (CANNOT CLAIM SHOCKS FROM CAR FINISHING BEHIND YOU)
- iii. REFUSAL TO ALLOW SHOCKS TO BE CLAIMED OR CONFISCATED BY OFFICIALS WILL RESULT IN THE DRIVER LOSING ALL POINTS AND MONEY FOR THAT EVENT, AND FACE THE FOLLOWING PUNISHMENT:
  1. **FIRST OFFENSE – 2-WEEK SUSPENSION FROM ANY MID-EAST SANCTIONED EVENT AND \$250 FINE**
  2. **SECOND OFFENSE – 30-DAY SUSPENSION FROM ANY MID-EAST SANCTIONED EVENT AND \$500 FINE**
  3. **THIRD OFFENSE – 365-DAY SUSPENSION FROM ANY MID-EAST SANCTIONED EVENT AND \$1,000 FINE**
- iv. SANCTIONING BODY AND/OR TRACK OFFICIALS MAY CONFISCATE OR CLAIM SHOCKS AT ANY TIME. IF CONFISCATED AND SHOCKS ARE DETERMINED TO BE LEGAL, THEY WILL BE RETURNED TO THE DRIVER AND POINTS AND MONEY WILL BE AWARDED AS EARNED. IF SHOCKS ARE DETERMINED TO BE ILLEGAL, THE DRIVER WILL LOSE ALL POINTS AND MONEY FROM THE EVENT AND FACE THE FOLLOWING PUNISHMENT:
  1. **FIRST OFFENSE – 2-WEEK SUSPENSION FROM ANY MID-EAST SANCTIONED EVENT AND \$250 FINE**
  2. **SECOND OFFENSE – 30-DAY SUSPENSION FROM ANY MID-EAST SANCTIONED EVENT AND \$500 FINE**
  3. **THIRD OFFENSE – 365-DAY SUSPENSION FROM ANY MID-EAST SANCTIONED EVENT AND \$1,000 FINE**

##### **3. THREE (3) ITEM "BOLT ON" PROTEST (\$300; \$100 ACCEPTANCE FEE, TRACK/SERIES RETAINS \$100. \$300 TO WINNER OF PROTEST)**

##### **4. TIRE PROTEST FEE (\$125)(\$125 ACCEPTANCE FEE, \$125 TO WINNER OF PROTEST, TRACK/SERIES RETAINS REMAINDER OF FEE TO PAY LAB)**

- a. TIRES NOT CONFORMING TO THE BENCHMARK WILL RESULT IN DISQUALIFICATION, LOSS OF POINTS AND PRIZE MONEY AS WELL AS:
  - i. **FIRST OFFENSE – 2 EVENT AND/OR 2 WEEK SUSPENSION FROM ANY MID-EAST SANCTIONED EVENT AND \$1000 FINE**
  - ii. **SECOND OFFENSE – 4 EVENT AND/OR 4 WEEK SUSPENSION FROM ANY MID-EAST SANCTIONED EVENT AND \$2000 FINE**
  - iii. **THIRD OFFENSE – 365 DAY SUSPENSION FROM ANY MID-EAST SANCTIONED EVENT AND FINE AT SANCTIONING BODY DISCRETION.**

##### **5. FUEL PROTEST FEE (\$150)(\$150 ACCEPTANCE FEE, \$150 TO WINNER OF PROTEST, TRACK/SERIES RETAINS REMAINDER OF FEE TO PAY LAB)**

- a. FUEL NOT CONFORMING TO THE BENCHMARK WILL RESULT IN DISQUALIFICATION, LOSS OF POINTS AND PRIZE MONEY AS WELL AS:
  - i. **FIRST OFFENSE – 2 EVENT AND/OR 2 WEEK SUSPENSION FROM ANY MID-EAST SANCTIONED EVENT AND \$1000 FINE**
  - ii. **SECOND OFFENSE – 4 EVENT AND/OR 4 WEEK SUSPENSION FROM ANY MID-EAST SANCTIONED EVENT AND \$2000 FINE**
  - iii. **THIRD OFFENSE – 365 DAY SUSPENSION FROM ANY MID-EAST SANCTIONED EVENT AND FINE AT SERIES DISCRETION.**

##### **6. PROTEST PROCESS**

- a. ONLY DRIVER/CAR OWNER MAY PROTEST. PROTESTING CAR MUST COMPETE IN RACE IN QUESTION TO FILE PROTEST. ALL PROTESTS MUST BE PRESENTED IN WRITING, ACCOMPANIED BY PROTEST FEE, TO THE TECH MAN WITHIN 5 MINS. OF THE WINNER OF THE FEATURE RACE CROSSING THE SCALES. PROTESTS DONE IN AN UNSPORTSMANLIKE MANNER WILL NOT BE CONSIDERED.
- b. PROTESTED CARS HAVE 5 MINS. TO ACCEPT OR REFUSE PROTEST. AFTER ACCEPTANCE, PROTESTED CAR HAS 5 MINS. TO BACK PULL PROTESTING CAR ONLY, ON EQUAL OR LESS ITEMS.
- c. TO PROTEST ANY CAR IN THE FIELD, YOU MUST FINISH DIRECTLY BEHIND THEM OR PROTEST ALL CARS BETWEEN. MUST BE ON LEAD LAP AT THE CHECKERED FLAG.
- d. AFTER PROTEST HAS BEEN FILED AND MONEY HAS BEEN PUT UP, IT WILL NOT BE RETURNED FOR ANY REASON. PROTEST CANNOT BE TAKEN DOWN ONCE IT IS FILED; THIS IS TO AVOID SWAPPING MONEY, WHICH IS UNFAIR TO THE REST OF THE FIELD.
- e. PARTS MUST BE READY FOR INSPECTION WITHIN ONE (1) HOUR. (TECH MAN DISCRETION)
- f. FOR PROTEST MONEY TO GO TO THE CAR THAT HAS BEEN PROTESTED, HE/SHE MUST TEAR DOWN AND BE CHECKED AND FOUND LEGAL. CARS FOUND ILLEGAL WILL FORFEIT POINTS AND MONEY EARNED FOR ENTIRE RACE NIGHT.
- g. QUESTIONS ON PROTEST PROCESS WILL BE MADE BY DRIVER/CAR OWNER ONLY.
- h. ONE CREW MEMBER FROM PROTESTING TEAM IS ALL THAT WILL BE ALLOWED IN TECH AREA OTHER THAN SECURITY AND TECH OFFICIALS FOR THE DURATION OF TECH PROCESS. NO SWITCHING OUT OF PROTESTING CREW MEMBER MID-TECH. NO PHONES OR CAMERAS ALLOWED IN TECH AREA WITH PROTESTING CREW MEMBER. IF CAUGHT ATTEMPTING TO TAKE PHOTOS, PROTESTING TEAM WILL BE DQ'ED. ALL PEOPLE IN TECH AREA SHALL REMAIN CALM & SPORTSMANLIKE DURING TECH PROCESS.
- i. THE TECH MAN HAS FINAL WORD ON ANY RULE OR PROTEST.

#### **11.17 ELECTRONIC DEVICES:**

1. NO DATA ACQUISITIONING DEVICES
2. NO TRACTION CONTROL OR LIKE DEVICES
  - a. MSD BOXES WILL BE CHECKED AND MAY BE IMPOUNDED AT ANY TIME
3. CAMERAS MUST BE MOUNTED ABOVE THE DECK AT ALL TIMES AND CLEAR OF DRIVERS VIEW

**RULE BOOK DISCLAIMER:** RULES AND/OR REGULATIONS SET FORTH HEREIN ARE DESIGNED TO PROVIDE FOR THE ORDERLY CONDUCT OF RACING EVENTS AND TO ESTABLISH MINIMUM ACCEPTABLE REQUIREMENTS FOR SUCH EVENTS. THESE RULES SHALL GOVERN ALL EVENTS, AND BY PARTICIPATING IN THESE EVENTS, ALL PARTICIPANTS ARE DEEMED TO HAVE COMPLIED WITH THESE RULES. NO EXPRESSED OR IMPLIED WARRANTY OF SAFETY SHALL RESULT FROM PUBLICATIONS OF OR COMPLIANCE WITH THESE RULES AND REGULATIONS. THEY ARE A GUIDE AND ARE IN NO WAY A GUARANTEE AGAINST INJURY OR DEATH TO A PARTICIPANT, SPECTATOR, OR OFFICIAL. MID EAST RETAINS THE RIGHT TO MAKE ALL DECISIONS AND RESERVES THE RIGHT TO MAKE ANY RULE CHANGES/AMENDMENTS WITH DISPUTE OR APPEAL. RULES WILL BE A LOOK AT BASED ON UNITED STATES AVAILABILITY. SOME ITEMS MAY BE LOOKED AT WITH VARIANCE DEPENDING ON UNITED STATES AVAILABILITY AS NECESSARY. "NITPICKING" WILL NOT BE TOLERATED, MID EAST MOTORSPORTS TECH OFFICIALS HAVE FINAL SAY.

BODY ILLUSTRATIONS:

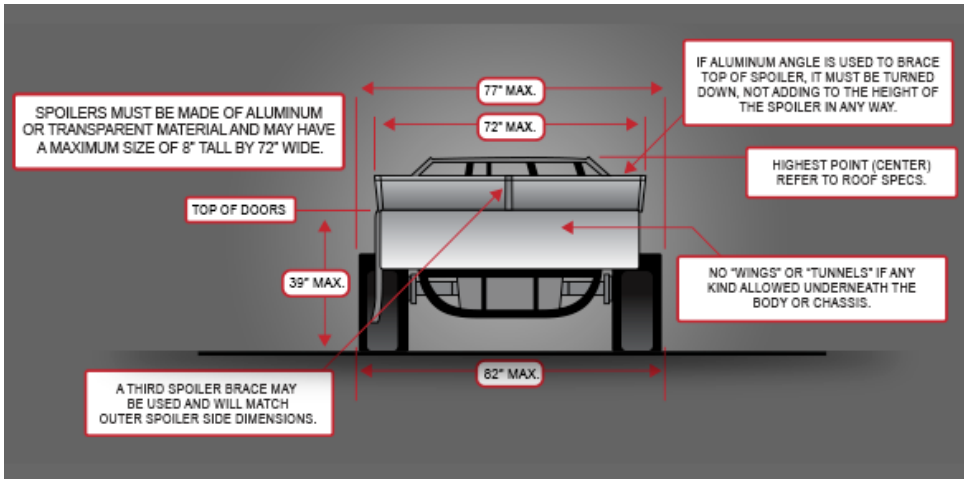
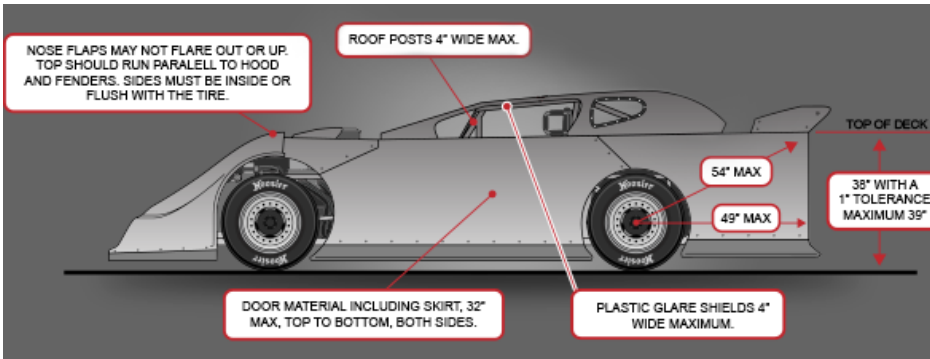
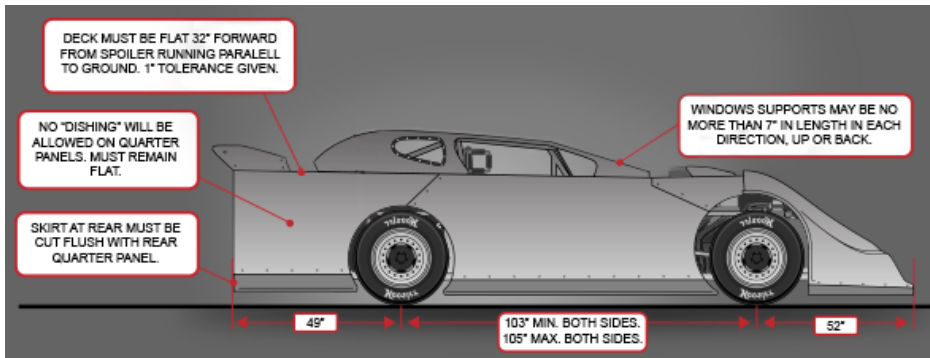



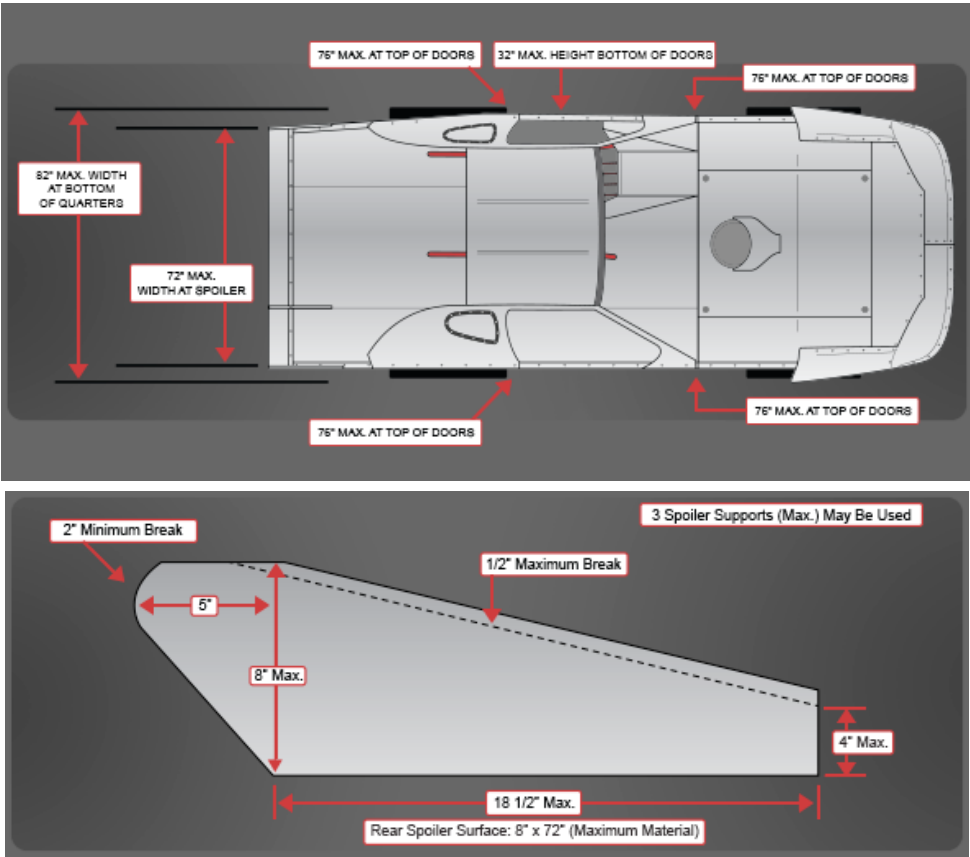

CHANGELOG:  
**12-7-21** UPDATED FOR 2022 RULES